

# **MYNOG**

## **Fundamental techniques of maintaining optical connections in the Multi-core connector (MPO)**

**NTT Advanced Technology Corporation**

# AGENDA

---

- About us
- Basics of Optical connection
- Summary of Return loss
- Cleaning the optical connector end face
- Cleaning demonstration

# NTT-AT's core expertise

We have more than 30 years experience to develop, manufacture, and sell products related to optical communications, such as manufacturing equipment and maintenance tools for components (optical connectors) that are important in optical fiber communications. We have deep knowledge and expertise of optical network especially physical layer.

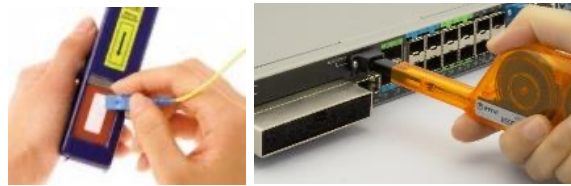

Optical Connector Cleaner



Physical layer switching device (Intelligent optical switch)

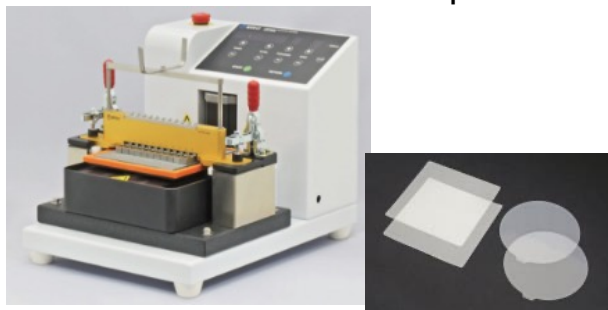

Optical connector polishing machine and polishing film



Optical adhesive

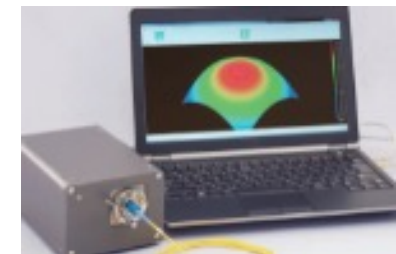

Optical connector measuring machine

---

# Basics

# Recent optical physical layer circumstances

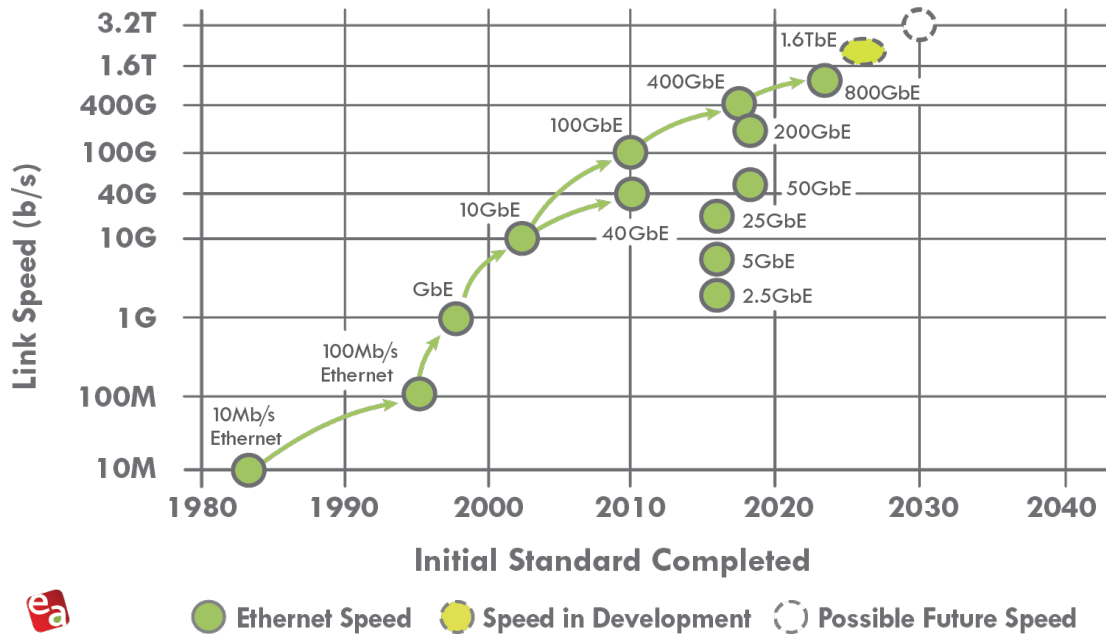

Higher speed Ethernet standards are being proposed, but (for now) transceiver interfaces always use optical connectors.

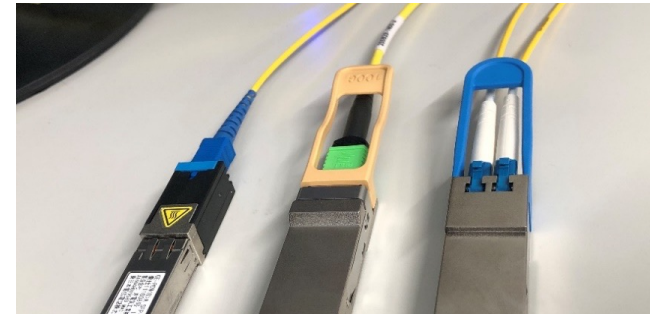

Excerpt from Ethernet Alliance Ethernet Roadmap 2024  
<https://ethernetalliance.org/technology/ethernet-roadmap/>

As communication speeds increase, a new problem of communication errors caused by "**return loss**" has become apparent in optical connector connections.

## Basics of optical connector

Optical connectors are parts for connecting and disconnecting optical fibers, and consist of a plug and an adapter.

It requires high precision to accurately connect small diameter optical fibers, low cost so that it can be used in large quantities in each part of the optical network, and ease of handling so that anyone can use it.

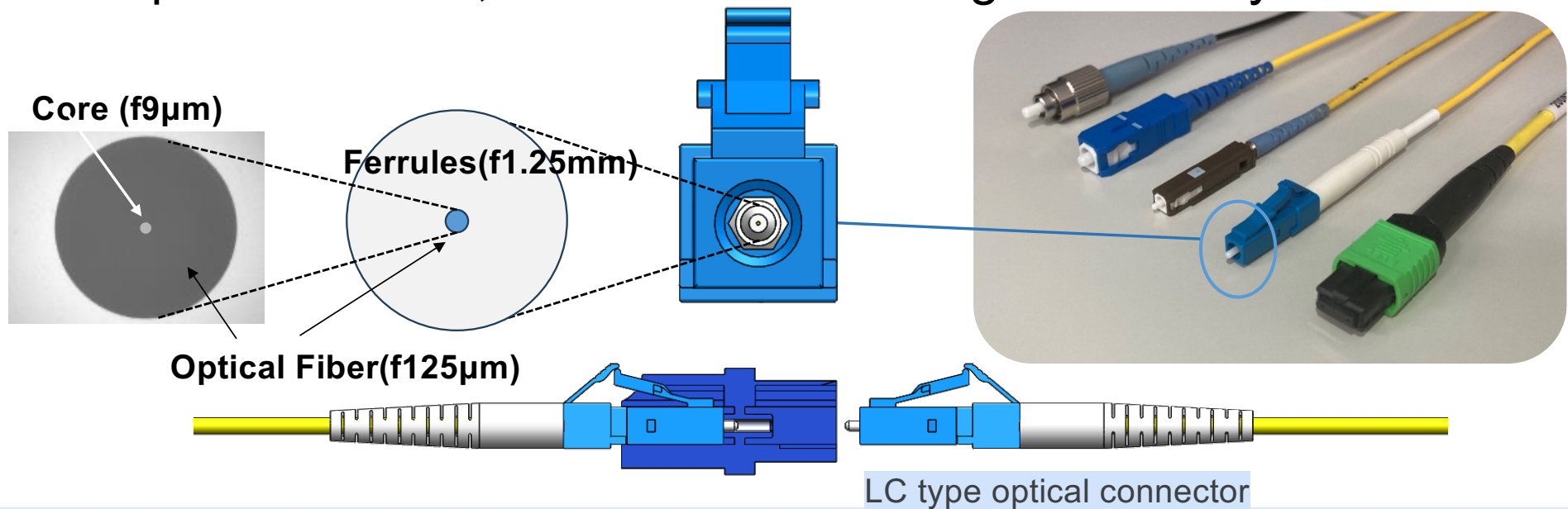

# List of major optical connectors

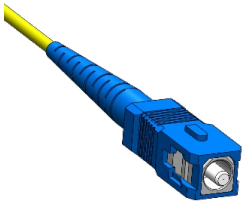
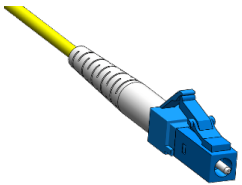
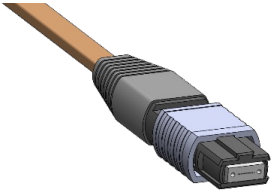
	SC	LC	MPO
appearance			
Ferrule Shape	Cylindric	Cylindric	Square
Diameter	2.5 mm	1.25 mm	6.5x2.4 mm
Fitting	Push-Pull	Latch	Push-Pull
Fiber Count	single core	single core	Multi core
Note	Telecom Global Standard	Datacom Global Standard	Datacom Popular in recent years

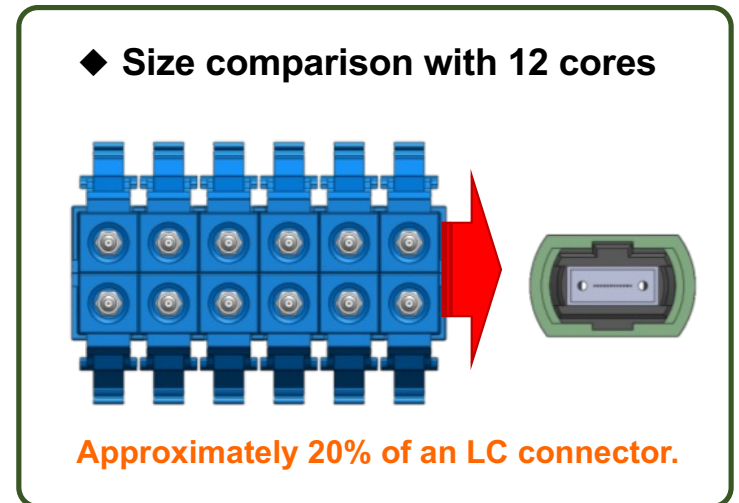

© Significantly improved storage efficiency.  
 × Deterioration in maintenance resolution.

MPO has dramatically changed the conventional concept of one connector, one fiber.

## Basic knowledge to get started with MPO connectors

---

The MPO connector has a completely different appearance and structure. There are some things you should know.

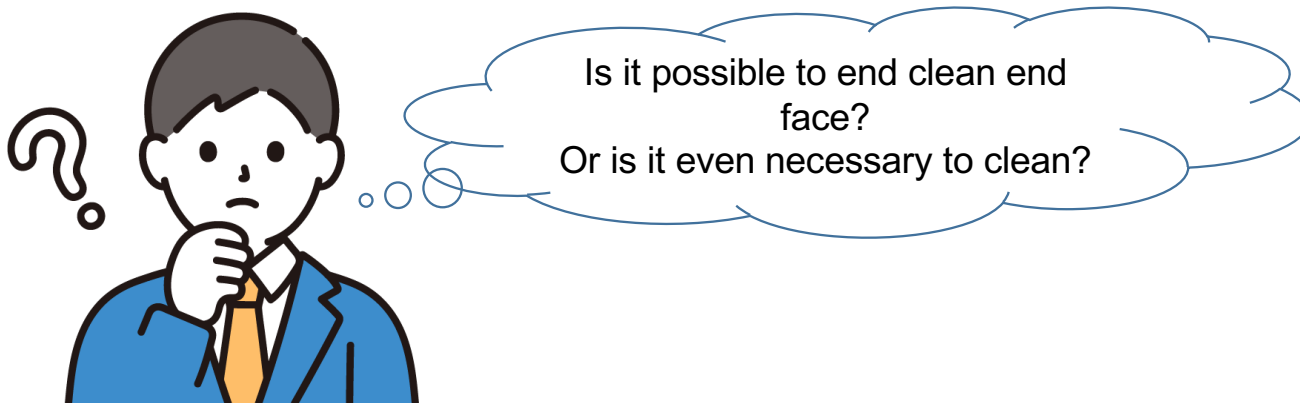

### The basic's of MPO connectors

# Differences in structure ①

## ◆ Structure of a single-core connector

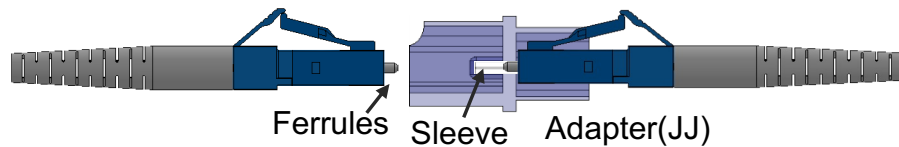

Align the same plugs with sleeves

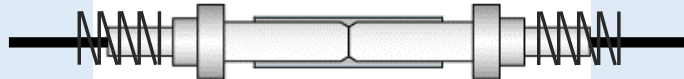

Physical contact with springs  
(close contact due to deformation  
of ferrule and fiber)

## ◆ Multi-core connector structure

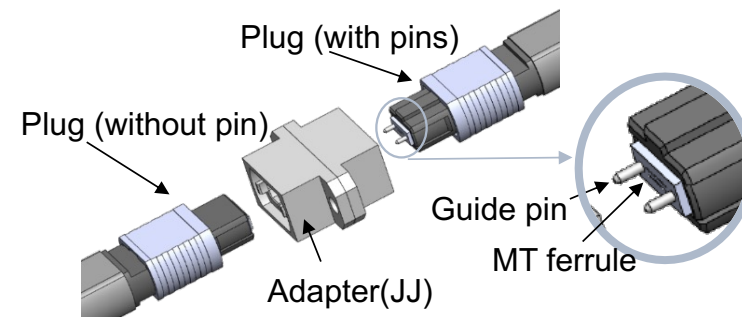

Plugs with different shapes are aligned with  
guide holes and guide pins

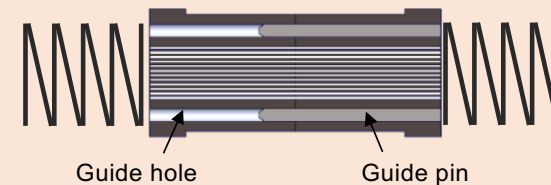

Physical contact with springs  
(close contact due to deformation  
of fiber)

# MPO Connector Types

## ◆ 12/24 core MPO connector

Key position (middle)

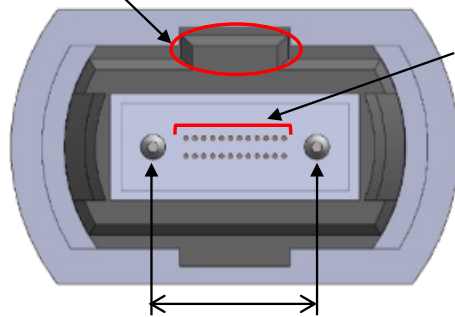

1 row for 12 cores  
2 rows for 24 cores

Guide hole pin :  $\phi 0.7\text{mm}$   
Pin pitch : 4.6 mm

## ◆ 16/32 core MPO connector

Key position (left)

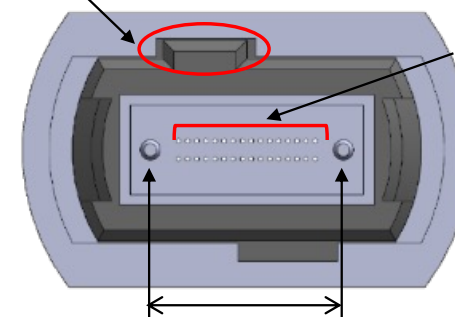





1 row for 16 cores  
2 rows for 32 cores

Guide hole pin :  $\phi 0.55\text{mm}$   
Pin pitch : 5.3 mm

**Connectors with different core counts cannot be physically connected due to differences in key positions.  
However, be aware that connector combinations with the same key positions (12 cores and 24 cores/16 cores and 32 cores) can be physically connected.**

# Next-generation optical connectors

	CS™ Connector	SN™ Connector	MDC™ Connector	SN™ MT Connector	MMC™ Connector
Appearance					
Ferrule Shape	Cylindrical	Cylindrical	Cylindrical	Square	Square
Diameter	1.25 mm/ 2 core	1.25 mm/ 2 core	1.25 mm/ 2 core	2 x 6.5 mm	2 x 6.5 mm
Fitting	Push-Pull	Push-Pull	Push-Pull	Push-Pull	Push-Pull
Note	2 core pitch = 3.8mm	2 core pitch = 3.1mm	2 core pitch = 3.1mm	8-core, 16-core	16-core, 24-core

*Please note: Photos are not same scale.*

**The basic usage remains the same**

CS Connector Source : <http://www.senko.com/cs-connector/>  
 SN Connector Source : <https://www.senko.com/sn-connector/>  
 MDC Connector Source : <https://www.usconec.com/featured-products/mdc-connectors>  
 SN-MT connector source : <https://www.senko.com/ja/sn-mt-series/>  
 MMC connector source : <https://www.usconec.com/featured-products/mmc-connector>  
 "CS" and "SN" are trademarks of SENKO ADVANCED COMPONENTS, INC.  
 "MDC" and "MMC" are trademarks of USConec Ltd.

# Next-generation VSFF (Very Small Form Factor) multi-fiber connector

Both are next-generation VSFF (Very Small Form Factor) multi-fiber connector that are increasingly being adopted for data centers and AI/HPC applications.

## ■ SN™ MT Connector



- Available in 8 fibers or 16 fiber configurations (dual-row arrangement)
- Achieves high-density deployment while maintaining the same footprint as the SN duplex connector
- Achieves 2.7 to 5.4 times the density of MPO

## ■ MMC™ Connector



- Available in 16 fiber or 24 fiber configurations
- The TMT ferrule is 30% thinner and 50% shorter than the standard MT ferrule
- Delivers approximately 3 times the density of MPO

---

To minimize loss in fiber connector

# Typical contamination on the end face of an optical connector

---

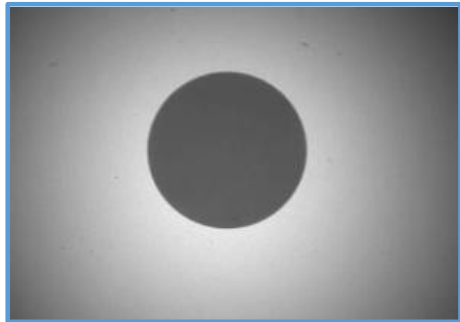

○Clean

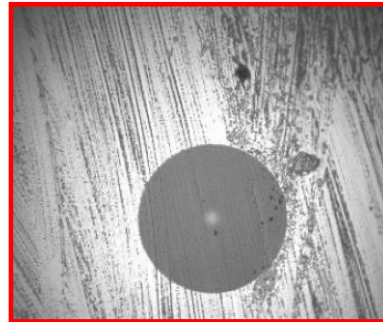

×Hand oil

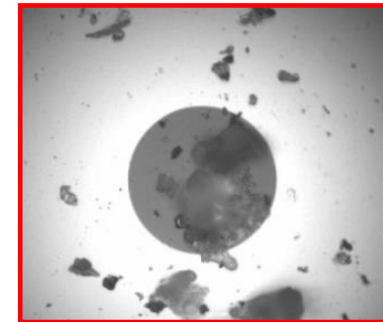

×Dust

## ◆ Characteristics of Optical Connectors

- Exposed optical fiber core ⇒ Easily accumulate contaminations
- Dust is not visible to the naked eye

## ◆ Typical types of contaminations

- Hand oil: Contact with fingers during work.
- Dust: Leaving the connector without a cap. Contact with racks, clothing, etc.

# Causes of poor optical properties

The majority of optical network problems that cause deterioration of optical characteristics are due to contamination of the connector.

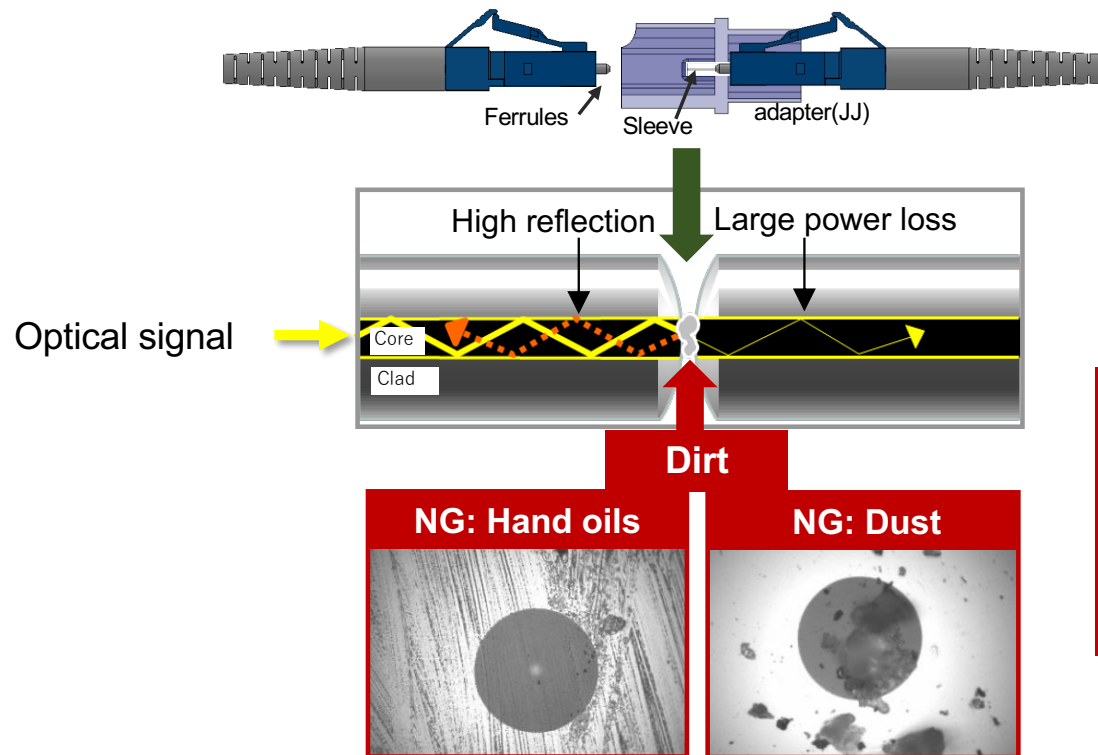

**Reflection and loss increase due to contaminations.**

# The effect of connector end face contamination on optical properties

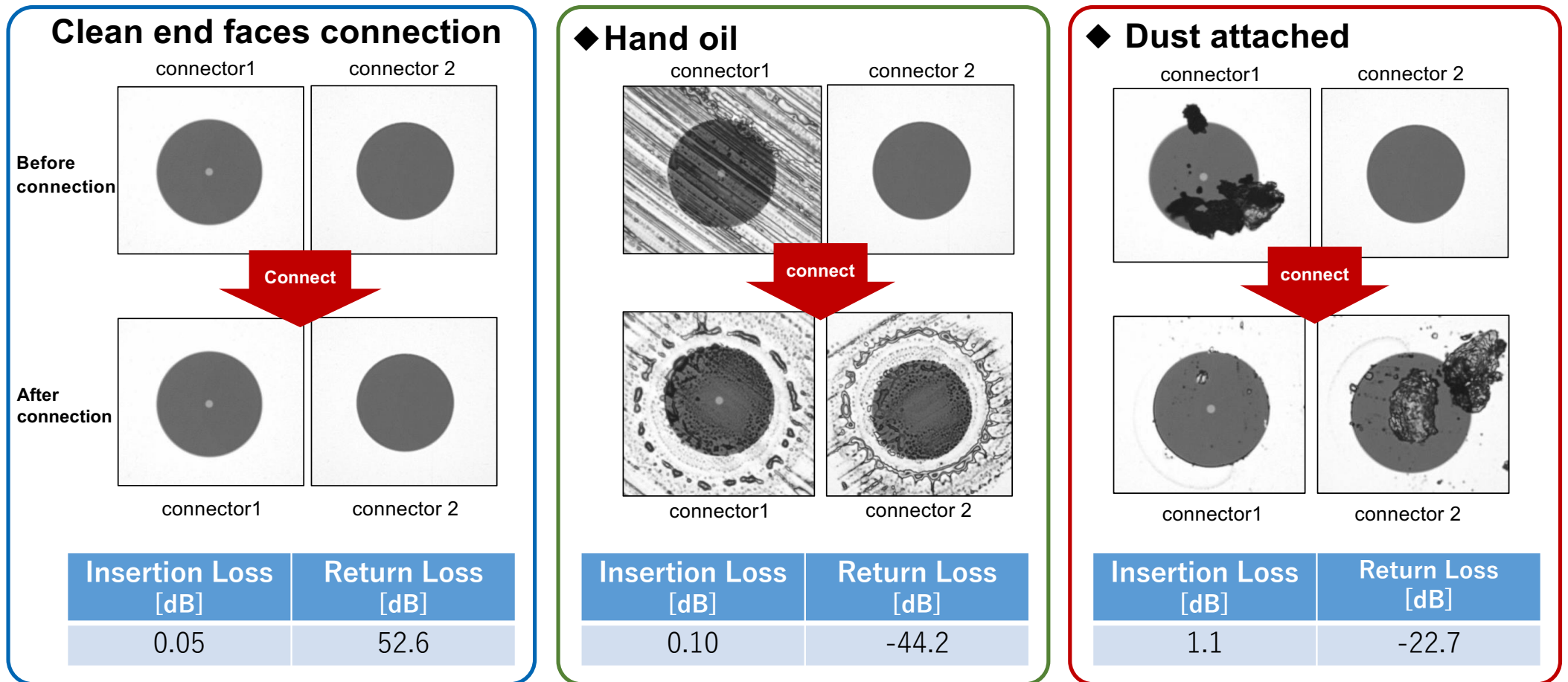

# Notes on guide pins on MPO

## ◆ When inserted and removed straight

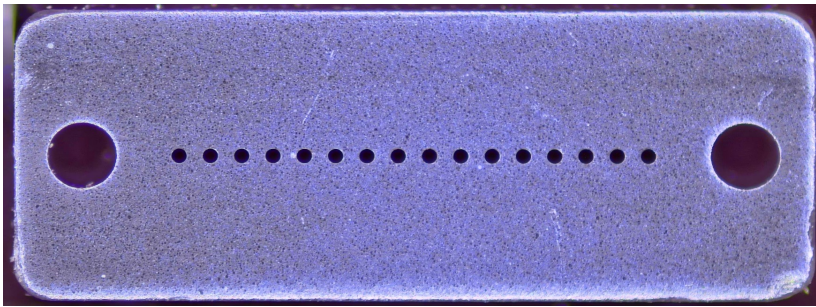

## ◆ When inserted or removed at an angle

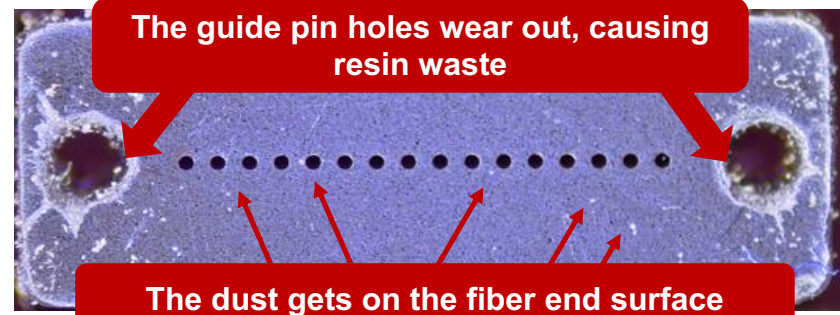

If the connector is not inserted and removed straightly, the area around the guide pin and hole will wear out and dirt will be generated.

It is important to insert and remove the connector carefully, and when inspecting the end face, it is also important to observe the area around the guide pin hole.

---

# Cleaning the optical connector end face

# Types of optical connector cleaners

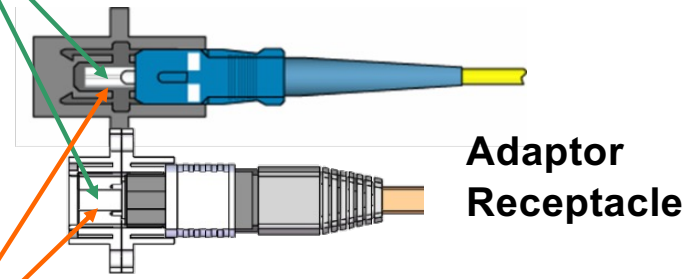
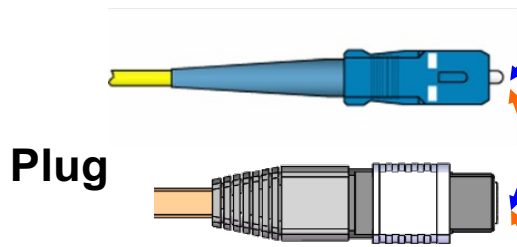

# Reel cleaner



## ◆ How to use

1. Open the shutter that protects the cleaning cloth.
2. Press the connector end face vertically against the cleaning cloth.
3. Slide it while still pressing it perpendicularly.

○ Replaceable cleaning cloths are cost effective

△ Only the plug can be cleaned

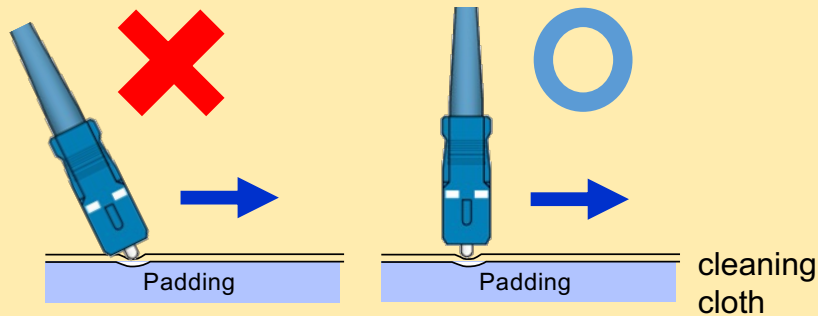

**Press the end face of the optical connector perpendicularly against the cleaning cloth while sliding it.**



MPO  
without pin

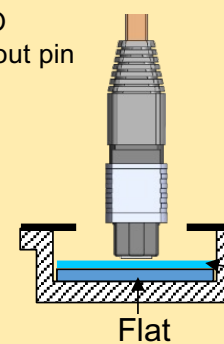

MPO  
with pin

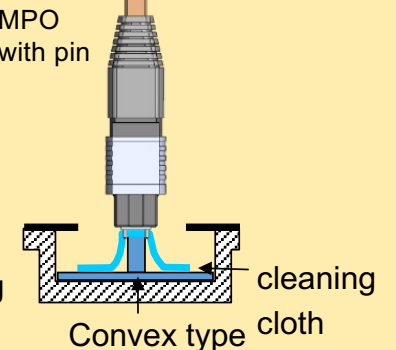

**\*The shape of the cleaner differs depending on whether or not it has a pin.**

# Stick type cleaner

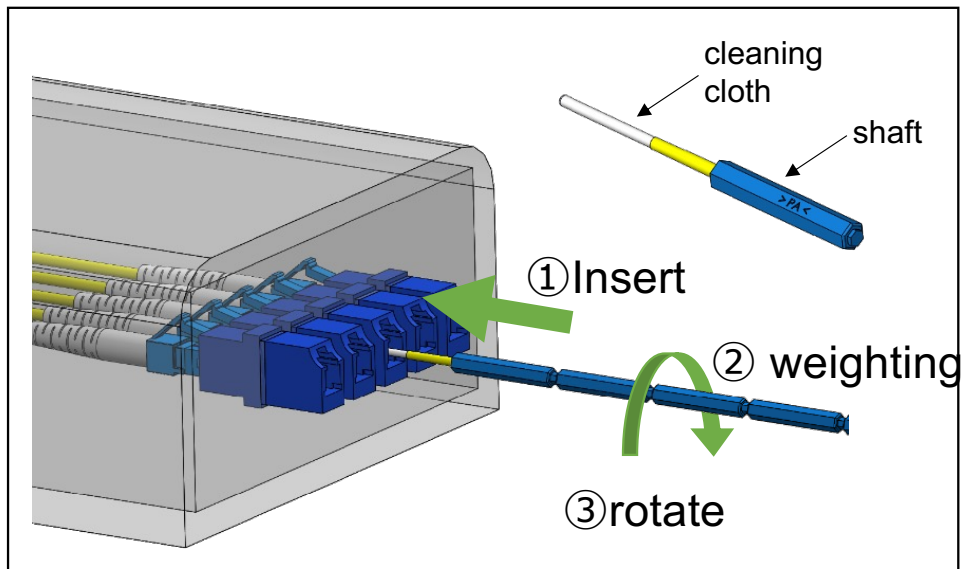

## ◆ How to use

- ① Insert straight into the adapter (JJ).
- ② Press against the ferrule.
- ③ Rotate 4 to 5 times in the same direction.

○ The front of the connector and the inside of the sleeve can be cleaned.

△ Differences can occur depending on individual skill levels.



The direction of rotation must be constant.



Basically, it is disposable after one use.

\*Reuse of a stick could risk that the dirt that was wiped off will be pushed back and contaminate the end surface.

# Pen type cleaner

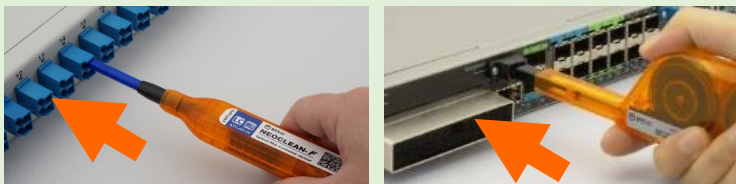

## ◆ How to use

- ① Remove the cap (attachment).
- ② Insert straight into the adapter (JJ).
- ③ Push it further in until it stops.

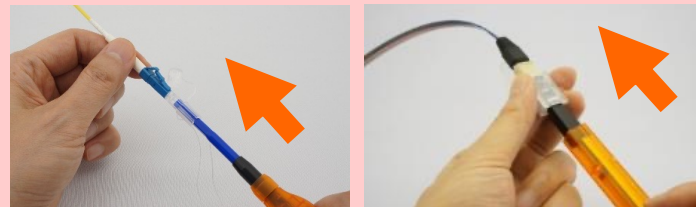

## ◆ How to use: Connector side

- ① Attach the cap (attachment)
- ② Insert the connector straight into the cap.
- ③ Push it in further until it stops.

- Does not depend on individual skill
- Can clean both connectors and device sides
- △ Cleaning range is center only



Once the cleaning thread has been used up, it will become harder to push in.  
\*If you force it in in this state, it may cause damage to the connector.

---

## **Live demo**

### **\* Cleaning demonstration**

**Shows the difference in the end surface before and after cleaning.**

Thank you

